

PATENTED SMART SRO RUBIDIUM SYNCLOCK+®
WITH INDUSTRY'S FIRST SMARTIMING+™ TECHNOLOGY INSIDE

Pascal Rochat, Bernard Leuenberger, Xavier Stehlin, Nino De Falcis

INTRODUCTION

With a breakthrough in technology, Temex introduces the industry's first smart Rubidium clock (SRO), integrating a host of complex timing and synchronization functionality all in one low-cost, ultra-small package.

The SRO SynClock+® intelligently synchronizes, disciplines, and controls any Stratum-1 reference such as GPS, Cesium, Hydrogen Maser, and T1/E1 at cutting-edge 1ns (nanosecond) resolution. The SynClock+® utilizes SmarTiming+™ technology to perform the following features, which were previously implemented externally on a separate circuit board:

- Multi-vendor GPS interface with auto-adaptive reference filtering, disciplining, control, and Time RAIM/Position Hold signal optimization
- Auto-adaptive Stratum-1 reference disciplining and jitter/wander/noise filtering between 0-100,000 at 1ns resolution, exceeding MTIE/TDEV G.823/T1.101 standards for T1/E1 reference
- Auto-adaptive frequency stability over fast temperature changes at 0.1°C resolution
- Auto-adaptive frequency stability over temperature range within 2E-11
- Programmable 1PPS output phase/time offset adjustments between 0-1 sec through a 1ns-phase comparator
- Programmable or hardware Sync/Track setting mode to either a) phase align 1PPSout from a 1PPS GPS reference through the Sync mode or b) to frequency track 1PPSout from a 1PPS Stratum-1 reference through the Track mode
- Programmable EEPROM for TIE performance measurements, frequency calibration and backup setting in case of power failure, and seamless software upgrades
- Standard RS-232 communication interface with user-friendly ASCII commands for control, configuration, fault, and performance management

SMART SRO RUBIDIUM SYNCLOCK+® MODEL

The smart SRO SynClock+® is designed with a standard Rb locked crystal oscillator using a Direct Digital Synthesizer (DDS) in its internal frequency control loop (see Fig. 1).

This model allows users or the SmarTiming+ microcontroller to adjust and sync the SRO's center frequency with a cutting-edge resolution of 5E-13 per step.

The SRO not only measures the relative phase of the PPS Ref, but it can also adjust its frequency to be aligned to it. Through its advanced analog ns-phase

comparator, the SRO can track a low-noise PPS Ref signal with a phase error of a few ns. Similarly, a noisy but stable signal can be tracked within a few ns. In this case, since the phase error is higher, the SRO's frequency is finely adjusted to the frequency of the PPS Ref. The SRO's frequency is stored in EEPROM memory. In case the PPS Ref disappears, the SRO continues to keep its frequency for many days with a phase error of less than a few μs. This is an ideal feature to sync a PPS signal from a GPS or track any other Stratum-1 references.

The SRO also has a multi-vendor GPS interface to optimize the signal quality through the Time RAIM and Position Hold data. The SmarTiming+ ns-phase comparator is used to compute the Allan Variance of the PPS Ref signal, enabling the SRO to filter the reference signal auto-adaptively by applying an optimal time constant to the tracking loop, regardless of the quality and behavior of the reference signal.

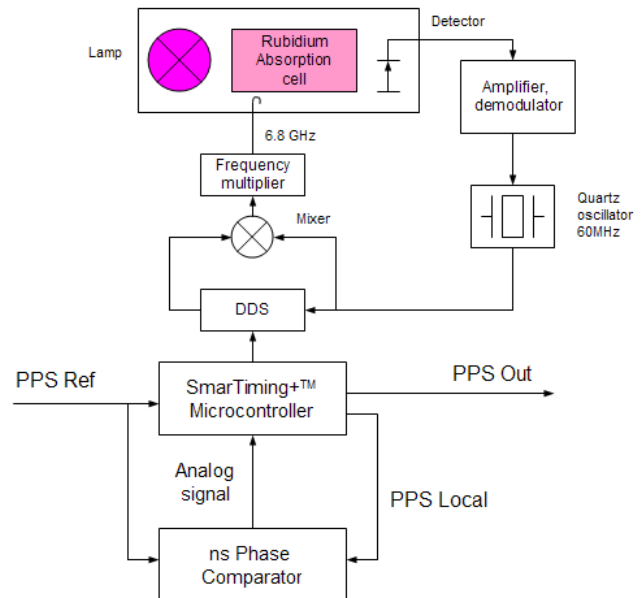

Fig. 1 Smart SRO Rubidium SynClock+® Model

The Smart SRO SynClock+® is uniquely able to sync a PPS Ref signal with a RMS noise up to microseconds, without a control device through the serial port (see Fig 2).

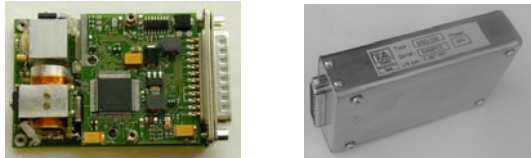

Fig. 2 Smart SRO-100/75 Rubidium SynClock+®

The SRO-100 and SRO-75 are pin and function compatible. The SRO-75 is 0.75" high. The SRO-100, which is 1" high, uses a standard Rb cell size, featuring a short-term stability performance of 1E-12² at 100 sec.

SRO SMARTIMING+ ALGORITHM TECHNOLOGY

The SRO uses SmarTiming+ algorithm technology in the µcontroller. The technology is based on the following Phase Frequency Loop model:

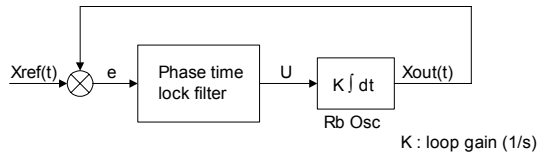

Fig. 3 SmarTiming+ Phase Frequency Loop Model

The smart Filtering Control model of the Proportional & Integral (PI) regulator is as follows:

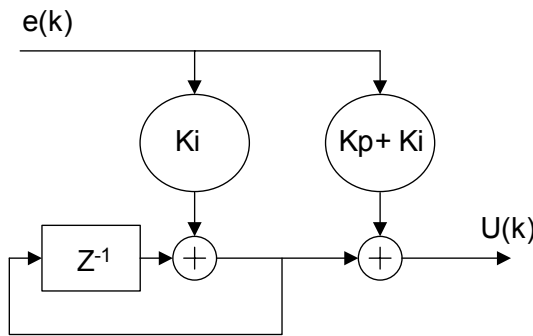

Fig. 4 SmarTiming+ Filtering Control Model

The applied filtering formula, which is based on the theory of Hansruedi Bühler (re: Réglages Echantillonnés, Presses Polytechniques Romandes 1982, p. 228) and equivalent analog filter theory, is as follows:

$$Ki = \frac{T_s}{K \cdot T_L^2} \quad \text{and} \quad Kp = \left(\frac{2 \cdot m \cdot T_L}{T_s} - \frac{1}{2} \right) \cdot Ki$$

Where:

T_s filter sampling period

T_L loop time constant
m dumping factor is 2

Since the value ½ is negligible in the formula, Kp becomes:

$$Kp = \frac{2 \cdot m}{K \cdot T_L}$$

The loop time constant (T_L) is defined based on the following model:

If T_L is too high, the phase error becomes too big. Conversely, if T_L is too low, the filtering is too poor.

The assumption is that the optimum point is when the reference noise has the same magnitude as the SRO noise.

As illustrated in Fig. 4, the T_L is optimum when the input reference noise line crosses the SRO's short-term stability. Thus the optimum T_{L1} formula becomes:

$$\sigma_{yRb}(1s) \cdot \tau^{-1/2} = \sigma_{yRef}(1s) \cdot \tau^{-1}$$

Hence: $T_{L1} = \left(\frac{\sigma_{yRef}(1s)}{\sigma_{yRb}(1s)} \right)^2$

- 10 ns rms input reference noise (GPS)
- - - SRO phase comparator stability
- SRO short term stability with +/- 3 °C temp. var.

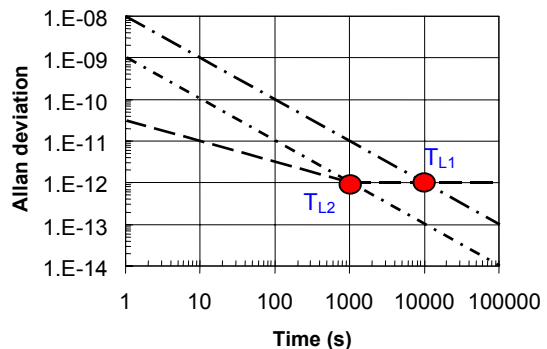

Fig.4 Typical GPS/SRO Stability Performance

However, since temperature variations have a key influence on long-term stability of any industrial Rb clock like the SRO, the optimum T_L point changes accordingly. To factor in this effect, the following formula applies:

$$\sigma_{yRb\theta} = \sigma_{yRef}(1s) \cdot \tau^{-1}$$

$$\text{Hence: } T_{L2} = \frac{\sigma_{yRef}(1s)}{\sigma_{yRb0}}$$

In real-life operation, the SRO's SmarTiming+ μ controller auto-adaptively sets its default loop time constant value to the lowest values between T_{L1} and T_{L2} .

SRO SMARTIMING+ PERFORMANCE

Fig. 5 illustrates the auto-adaptive filtering performance of the SRO's SmarTiming+ technology. A noisy PPS Ref is generated by a standard Hydrogen-Maser reference system, which includes a synthesizer and a 10MHz/1PPS divider. The synthesizer is modulated in phase through a random sequence.

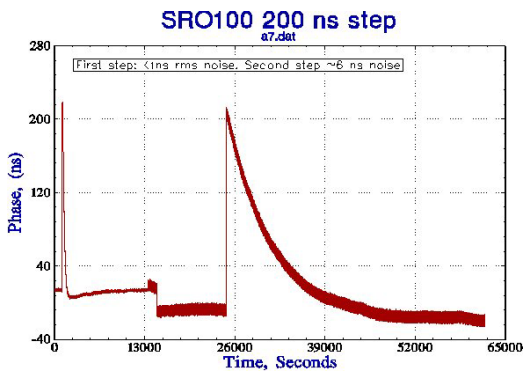

Fig. 5 SmarTiming+ Filtering Response

TYPICAL GPS REFERENCE PERFORMANCE

Fig. 6 and 7 illustrate the typical GPS performance of a Motorola UT+ OnCore and a Navman Jupiter T receiver. The measurements were performed against the Hydrogen Maser standard reference (model H-MASER EFOS-C) of Temex Neuchatel Time.

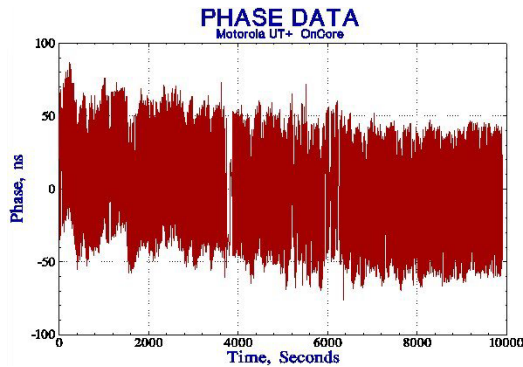

Fig. 6 Motorola GPS UT+ OnCore Performance

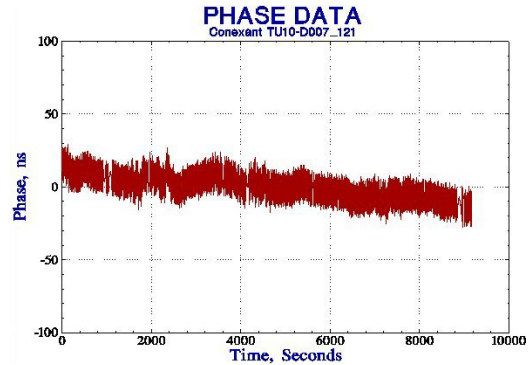

Fig. 7 Navman/Jupiter T GPS Performance

The signal of the Motorola GPS is very noisy. The noise can be partially removed by subtracting the negative sawtooth, which can be performed through the SRO command: @@En., Time RAIM status message. The downward slope of both plots is due to the frequency offset of the Hydrogen Maser reference.

SMART SRO SHORT-TERM STABILITY IN FREE-RUN MODE

Fig 8 and 9 illustrate the short-term stability of a smart SRO in free-run mode - i.e. not locked to a GPS or Stratum-1 reference. The SRO 10MHz phase stability was measured against a 10 MHz Hydrogen Maser reference. The phase comparator was a PicoTime test set designed by Temex Time. The tests were performed in a non-air-conditioned lab.

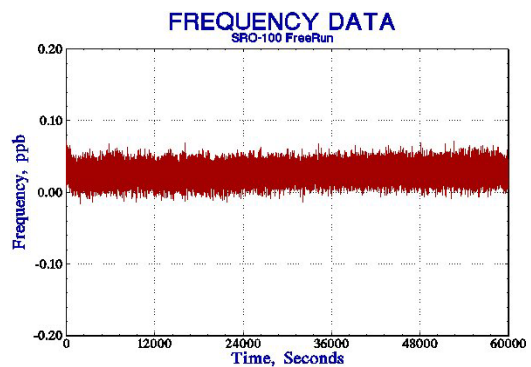

Fig. 8 Smart SRO Frequency Stability Performance in Free-Run Mode

Fig. 10 Smart SRO Frequency Stability Performance when Locked to a Hydrogen Maser Reference

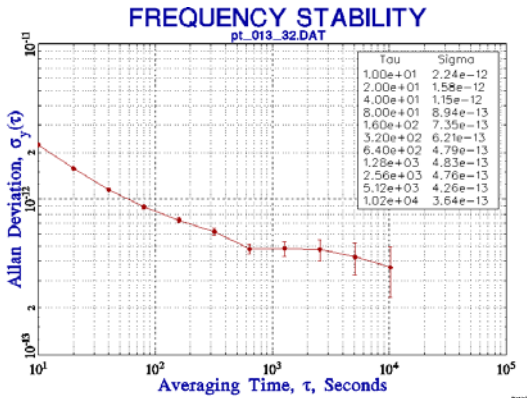

Fig. 9 Smart SRO Frequency Stability Performance in Free-Run Mode

SMART SRO SHORT-TERM STABILITY IN LOCKING MODE

Fig 10 and 11 illustrate the short-term stability of a smart SRO when locked with difference Stratum-1 references.

The figures show that the auto-adaptive SmartTiming+ filtering does not add noise. When the SRO is locked to a low-noise PPS Ref, the phase error is less than a few ns. In this case, the 1000 sec loop time constant is automatically set by the micro-controller and the short-term stability is improved above 1000 sec.

When locked to a PPS Ref from the Navman GPS, the phase error is within +/- 100 ns. The behavior of Fig 10 and 11 beyond 1000 sec is only due to temperature fluctuations in the lab during the tests.

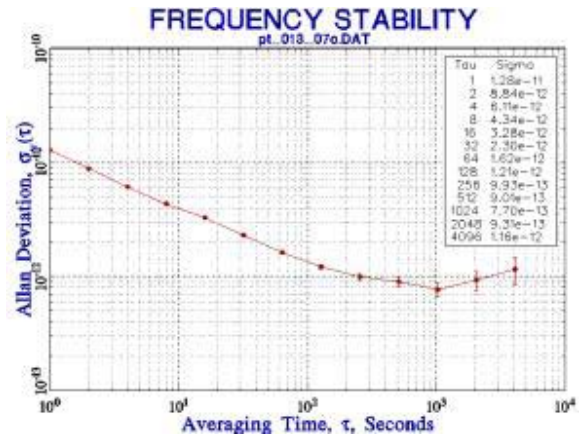

Fig. 11 Smart SRO Frequency Stability Performance when Locked to a Navman GPS

SMART SRO HOLDOVER PERFORMANCE

Fig 12 illustrates a smart SRO in holdover mode. The SRO was left during some days in an oven, tracking a PPS Ref from a Hydrogen Maser reference. Then the SRO was set to free running mode by sending a simple command through the RS-232 port.

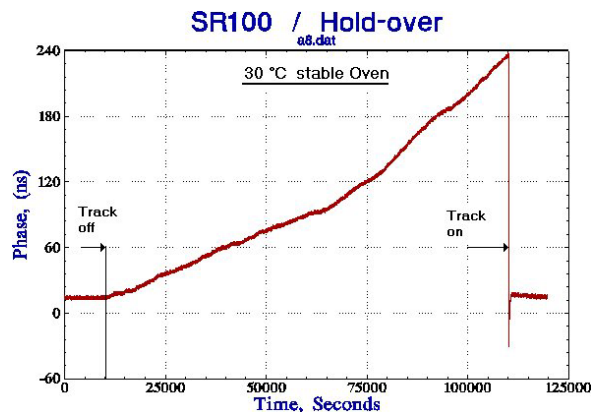
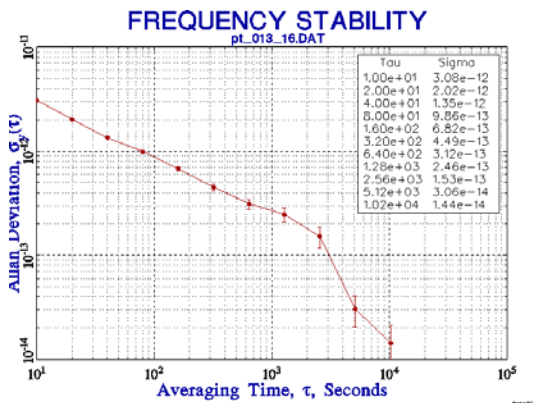

Fig. 12 Smart SRO Holdover Performance

Taking into account the drift rate of about 1E-12/day and the frequency over temperature sensitivity of about 1E-12/°C, The smart SRO is able to maintain a holdover performance of less than 1 μs over one day in normal lab conditions.



SMART RUBIDIUM CLOCK TECHNOLOGY WHITE PAPER



CONCLUSION

The smart SRO SynClock+® is a breakthrough technology, which provides core time, frequency, and synchronization functionality all in one low-cost package.

The auto-adaptive SmarTiming+ technology allows designers to have a plug-&-play solution, eliminating the need for designing an external reference locking, disciplining and control system.